

VTT EXPERT SERVICES OY  
PL 1001  
02044 VTT  
Tel. + 358 20 722 111  
[www.vttexpertservices.fi](http://www.vttexpertservices.fi)



Rakennusalan tuotteita koskevan jäsen-  
valtioiden lainsäädännön lähentämisestä 21  
päivänä joulukuuta 1988 annetun neuvoston  
direktiivin 89/106/EEC mukaisesti ilmoitettu  
tuotehyväksyntälaitos

**EOTAN JÄSEN**

## **Eurooppalainen tekninen hyväksyntä ETA-10/0280** European Technical Approval

**Kauppanimi:**  
Trade name

**Apolo MEA Quick fix anchors**  
**BAZ, BAZ A4, BAZ HD, BAZ HCR**

**Hyväksynnän haltija:**  
Holder of approval:

**Apolo MEA Befestigungssysteme GmbH**  
**Industriestr. 6**  
**86356 Aichach, Germany**

**Tuotetyyppi ja sen käyttötarkoitus:**  
Generic type and use of construction  
product:

**Torque controlled expansion anchors of sizes M8, M10,  
M12 and M16 for use in concrete**

**Voimassaoloaika:**  
Validity from/to:

**From 5.6.2013 to 4.6.2018**

**Tämä korvaa:**  
This version replaces:

**ETA-10/0280 valid from July 15, 2010 to May 19, 2014**

**Valmistuspaikka:**  
Manufacturing plants:

**Plant 7**

**Tämä hyväksyntä sisältää**  
This European Technical Approval  
contains

sivuja/liitteitä

16 sivua sisältäen 8 liitettä

pages/annexes

16 pages including 8 annexes



Eurooppalainen tekninen hyväksyntäorganisaatio  
European Organisation for Technical Approvals

## I LEGAL BASIS AND GENERAL CONDITIONS

1. This European Technical Approval is issued by VTT Expert Services Ltd in accordance with:
  - Council Directive 89/106/EEC of 21 December 1988 on the approximation of laws, regulations and administrative provisions of Member States relating to construction products<sup>1</sup>, modified by Council Directive 93/68/EEC<sup>2</sup> and Regulation (EC) N° 1882/2003 of the European Parliament and of the Council<sup>3</sup>;
  - Laki rakennustuotteiden hyväksynnästä (230/2003) luvut 3 ja 10, Ympäristöministeriön asetus rakennustuotteiden hyväksynnästä 3 § sekä Ympäristöministeriön 18.12.2009 antama valtuutuspäätös (YM19/629/2009).
  - Common Procedural Rules for Requesting, Preparing and the Granting of European Technical Approvals set out in the Annex of Commission Decision 94/23/EC<sup>4</sup>;
  - Guideline Nr 001 for European Technical Approval of “Metal Anchors for use in Concrete“ ETAG 001, edition 1997, Part 1 ”Anchors in general”, and Part 2 “Torque-controlled expansion anchors” and EOTA Technical report TR 020, May 2004.
2. VTT Expert Services Ltd is authorized to check whether the provisions of this European Technical Approval are met. Checking may take place in the manufacturing plant. Nevertheless, the responsibility for the conformity of the products to the European Technical Approval and for their fitness for the intended use remains with the holder of the European Technical Approval.
3. This European Technical Approval is not to be transferred to manufacturers or agents of manufacturer other than those indicated on page 1, or manufacturing plants other than those indicated on page 1 of this European Technical Approval
4. This European Technical Approval may be withdrawn by VTT Expert Services Ltd pursuant to information by the Commission according to Article 5(1) of Council Directive 89/106/EEC.
5. Reproduction of this European Technical Approval including transmission by electronic means shall be in full. However, partial reproduction can be made with the written consent of VTT Expert Services Ltd. In this case partial reproduction has to be designated as such. Texts and drawings of advertising brochures shall not contradict or misuse the European Technical Approval.
6. The European Technical Approval is issued by the approval body in English. This version corresponds fully to the version circulated in EOTA. Translations in other languages have to be designated as such.

---

<sup>1</sup> Official Journal of the European Communities N° L 40, 11.2.1989, p. 12

<sup>2</sup> Official Journal of the European Communities N° L 220, 30.8.1993, p. 1

<sup>3</sup> Official Journal of the European Union N° L 284, 31.10.2003, p. 1

<sup>4</sup> Official Journal of the European Communities N° L 17, 20.1.1994, p. 34

## **II SPECIFIC CONDITIONS OF THE EUROPEAN TECHNICAL APPROVAL**

### **1 Definition of product and intended use**

#### **1.1 Definition of the construction product**

The Apolo MEA Quick fix anchor BAZ is an anchor made of galvanised steel (designated as BAZ). The Apolo MEA Quick fix anchor BAZ HD is an anchor made of hot dip galvanized steel (designated as BAZ HD). The Apolo MEA Quick fix anchor BAZ A4 is an anchor made of stainless steel (designated as BAZ A4). The Apolo MEA Quick fix anchor BAZ HCR is an anchor made of high corrosion resistant stainless steel (designated as BAZ HCR). The anchors are made in sizes M8, M10, M12 and M16. Anchors are placed into a drilled hole and anchored by torque-controlled expansion.

An illustration of the products and intended use is given in Annex 1.

#### **1.2 Intended use**

The anchors are intended to be used for anchorages for which requirements for mechanical resistance and stability and safety in use in the sense of the Essential Requirements 1 and 4 of Council Directive 89/106/EEC shall be fulfilled and failure of anchorages made with these products would compromise the stability of the works, cause risk to human life and/or lead to considerable economic consequences.

The anchors may be used for anchorages with requirements related to resistance to fire.

The anchor is to be used only for anchorages subject to static or quasi-static loading in reinforced or unreinforced normal weight concrete of strength classes C 20/25 at minimum and C50/60 at the most according to EN 206: 2000-12. It may be anchored in cracked and non-cracked concrete.

The Apolo MEA BAZ and Apolo MEA BAZ HD anchors may only be used in concrete subject to dry internal conditions.

The Apolo MEA BAZ A4 anchor may be used in structures subject to dry internal conditions and also in structures subject to external atmospheric exposure (including industrial and marine environments), or exposure in permanently damp internal conditions, if no particular aggressive conditions exist. Such particular aggressive conditions are e.g. permanent, alternating immersion in seawater or the splash zone of seawater, chloride atmosphere of indoor swimming pools or atmosphere with chemical pollution (e.g. road tunnels where de-icing materials are used).

The Apolo MEA BAZ HCR anchor may be used in structures subject to dry internal conditions and also in structures subject to external atmospheric exposure, in permanently damp internal conditions or in other particular aggressive conditions. Such particular aggressive conditions are e.g. permanent, alternating immersion in seawater or the splash zone of seawater, chloride atmosphere of indoor swimming pools or atmosphere with chemical pollution (e.g. in desulphurization plants or road tunnels where de-icing materials are used).

The provisions made in this European Technical Approval are based on an assumed intended working life of the anchor of 50 years. The indications given on the working life cannot be interpreted as a guarantee given by the producer, but are to be regarded only as a means for

choosing the right products in relation to the expected economically reasonable working life of the works.

## **2 Characteristics of product and methods of verification**

### **2.1 Characteristics of product**

The anchor in the range of M8 to M16 corresponds to the drawings and provisions given in Annexes 1 to 4. The characteristic material values, dimensions and tolerances of the anchor not indicated in Annexes 1 to 4 shall correspond to the respective values laid down in the technical documentations<sup>5</sup> of this European Technical Approval.

Regarding the requirements concerning safety in case of fire it is assumed that the anchor meets the requirements A1 in relation to the reaction to fire in accordance with the stipulations in the Commission decision 96/603/EC, amended in 2000/605/EC.

The characteristic anchor values for the design of anchorages are given in Annexes 5 and 6.

The characteristic values for the design of anchorages regarding resistance to fire are given in the Annexes 7 and 8. They are valid for use in the system that is required to provide a specific fire resistance class.

Each anchor is marked with the identifying mark of the producer in a shortened way, the anchor identity, the category, the size of thread, the maximum thickness of fixture and the used material according to Annexes 1 and 4.

The anchor shall only be packaged and supplied as a complete unit.

### **2.2 Methods of verification**

The assessment of fitness of the anchor for the intended use in relation to the requirements for mechanical resistance and stability and safety in use in the sense of the Essential Requirements 1 and 4 has been made in accordance with the "Guideline for European Technical Approval of Metal Anchors for use in Concrete", Part 1 "Anchors in general", and Part 2, "Torque-controlled expansion anchors" on the basis of Option 1.

The assessment of the anchors for the intended use in relation to the requirements for resistance to fire has been made in accordance with the Technical report TR 020 "Evaluation of anchorages in concrete concerning resistance to fire"

In addition to specific clauses relating to dangerous substances contained in this European technical approval, there may be other requirements applicable to the products falling with its scope (e.g. transposed European legislation and national laws, regulations and administrative provisions). In order to meet the provisions of the Construction Products Directive, these requirements need also to be compiled with, when and where they apply.

---

<sup>5</sup> The technical documentation of this European Technical Approval is deposited at VTT Expert Services Ltd and, as far as relevant for the tasks of the approved bodies involved in the attestation of conformity procedure, is handed over to the approved bodies.

### **3 Evaluation and attestation of conformity and CE marking**

#### **3.1 System of attestation of conformity**

The system of attestation of conformity 2 (i) (referred to as system 1) according to Council Directive 89/106/EEC Annex III laid down by the European Commission provides:

- (a) Tasks for the manufacturer:
  - (1) factory production control;
  - (2) further testing of samples taken at the factory by the manufacturer in accordance with a prescribed test plan;
  
- (b) Tasks for the approved body:
  - (3) initial type-testing of the product;
  - (4) initial inspection of factory and of factory production control;
  - (5) continuous surveillance, assessment and approval of factory production control.

#### **3.2 Responsibilities**

##### **3.2.1 Tasks of the manufacturer**

###### **3.2.1.1 Factory production control**

The manufacturer has a factory production control system in the plant and exercises permanent internal control of production. All the elements, requirements and provisions adopted by the manufacturer are documented in a systematic manner in the form of written policies and procedures. This production control system ensures that the product is in conformity with the European Technical Approval.

The manufacturer shall only use raw materials supplied with the relevant inspection documents as laid down in the control plan<sup>6</sup>.

The factory production control shall be in accordance with the control plan of May 2009 which is the part of the technical documentation of this European technical approval. The control plan is laid down in the context of the factory production control system operated by the manufacturer and deposited at VTT Expert Services Ltd<sup>6</sup>.

The results of factory production control shall be recorded and evaluated in accordance with the provisions of the control plan.

###### **3.2.1.2 Other tasks for the manufacturer**

The manufacturer shall, on the basis of contract, involve a body which is approved (notified) for the tasks referred to in section 3.1 in the field of anchors in order to undertake the actions laid down in sections 3.2.2.. For this purpose, the control plan referred to in sections 3.2.1.1 and 3.2.2 shall be handed over by the manufacturer to the approved body involved.

---

<sup>6</sup> The control plan is a confidential part of the documentation of the European technical approval, and not published together with the ETA, and is only handed over to approved body involved in the conformity attestation procedure.

The manufacturer shall make a declaration of conformity, stating that the construction product is in conformity with the provisions of this European technical approval.

### 3.2.2 Tasks of approved bodies

#### 3.2.2.1 Initial type-testing of the product

For initial type-testing the results of the tests performed as part of the assessment for the European Technical Approval shall be used unless there are changes in the production line or plant. In such cases the necessary initial type-testing has to be agreed between VTT Expert Services Ltd and the approved bodies involved.

#### 3.2.2.2 Initial inspection of factory and of factory production control

The approved body shall ascertain that, in accordance with the control plan, the factory and the factory production control are suitable to ensure continuous and orderly manufacturing of the anchor according to the specifications mentioned in 2.1. as well as in the Annexes to the European Technical Approval, in accordance with the control plan.

#### 3.2.2.3 Continuous surveillance

The approved body shall visit the factory at least once a year for regular inspection. It has to be verified that the system of factory production control and the specified automated manufacturing process are maintained taking account of the control plan.

Continuous surveillance and assessment of factory production control have to be performed according to the control plan.

The results of product certification and continuous surveillance shall be made available on demand by the certification body or inspection body, respectively, to VTT Expert Services Ltd.

In cases where the provisions of the European Technical Approval and the prescribed test plan are no longer fulfilled the conformity certificate shall be withdrawn.

### 3.3 CE-Marking

The CE marking shall be affixed on each packaging of anchors. The symbol "CE" shall be accompanied by the following information:

- identification number of the certification body;
- name or identifying mark of the producer and manufacturing plant;
- the last two digits of the year in which the CE-marking was affixed;
- number of the EC certificate of conformity;
- number of the European Technical Approval; ETA-10/0280
- use category (ETAG 001-1 Option 1);
- size.

## **4 Assumptions under which the fitness of the product for the intended use was favourably assessed**

### **4.1 Manufacturing**

The anchor is manufactured in accordance with the provisions of the European Technical Approval using the automated manufacturing process as identified during the inspection of the plant by VTT Expert Services Ltd and the approved body and laid down in the technical documentation.

### **4.2 Installation**

#### 4.2.1 Design of anchorages

The fitness of the anchors for the intended use is given under the following conditions:

The anchorages are designed in accordance with the "Guideline for European Technical Approval of Metal Anchors for Use in Concrete", Annex C, Method A, for torque controlled expansion anchors under the responsibility of an engineer experienced in anchorages and concrete work.

Verifiable calculation notes and drawings are prepared taking account of the loads to be anchored.

The position of the anchor is indicated on the design drawings (e.g. position of the anchor relative to reinforcement or to support, in cracked or non-cracked concrete, etc.).

The design of anchorages under fire exposure has to consider conditions given in Technical report TR 020 "Evaluation of anchorages in concrete concerning resistance to fire". The relevant characteristic anchor values are given in the Annexes 7 and 8. The design method covers anchors with a fire attack from one side only. If the fire attack is from more than one side, the design method may be taken only, if the edge distance of the anchor is  $c \geq 300$  mm.

#### 4.2.2 Installation of anchors

The fitness for use of the anchor can only be assumed if the anchor is installed as follows:

- Anchor installation carried out by appropriately qualified personnel and under the supervision of the person responsible for technical matters on the site.
- Use of the anchor only as supplied by the manufacturer without exchanging the components of an anchor.
- Anchor installation in accordance with the manufacturer's specifications and drawings prepared for that purpose and using the appropriate tools.
- Thickness of the fixture corresponding to the range of required thickness value for the type of anchor
- Checks before placing the anchor to ensure that the strength class of the concrete in which the anchor is to be placed is in the range given and is not lower than that of the concrete to which the characteristic loads apply.
- Check of concrete being well compacted, e.g. without significant voids.
- Clearing the hole of drilling dust.

- Keeping of the edge distance and spacing to the specified values without minus tolerances.
- Positioning of the drill holes without damaging the reinforcement.
- In case of aborted hole: new drilling at a minimum distance away of twice the depth of the aborted hole or smaller distance if the aborted drill hole is filled with high strength mortar and if under shear or oblique tension load it is not in the direction of load application.
- Application of the torque moment given in Annex 4 using a calibrated torque wrench.

#### 4.2.3 Responsibility of the manufacturer

It is the manufacturer's responsibility to ensure that the information on the specific conditions according to 1 and 2 including Annexes referred to in 4.2.1 and 4.2.2 is given to those who are concerned. This information may be made by reproduction of the respective parts of the European Technical Approval. In addition all installation data shall be shown clearly on the package and/or on an enclosed instruction sheet, preferably using illustration(s).

The minimum data required are:

- drill bit diameter,
- thread diameter,
- maximum thickness of the fixture,
- minimum effective anchorage depth,
- minimum hole depth,
- required torque moment,
- information on the installation procedure, including cleaning of the hole, preferably by means of an illustration,
- reference to any special installation equipment needed,
- identification of the manufacturing batch.

All data shall be presented in a clear and explicit form.

On behalf of VTT Expert Services Ltd

Espoo, July 5, 2013



Lina Markelin-Rantala  
Team Manager



Liisa Rautiainen  
Assessment Manger



### Apolo MEA Quick fix anchor

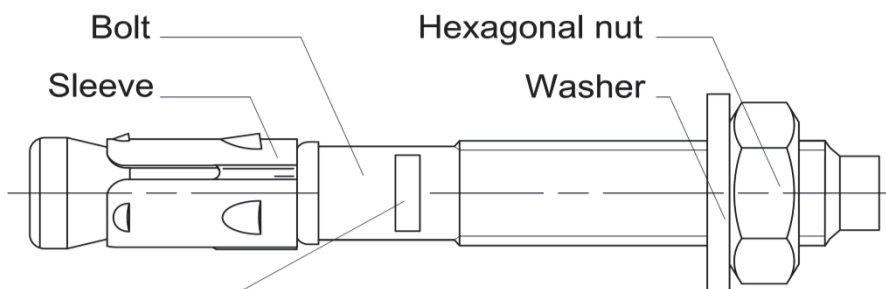

**Marking:** Identifying mark: S  
 Anchor identity: KA  
 Category<sup>\*1)</sup>: H (stainless steel)  
 K (hot dip galvanized)  
 Thread size: M8 ... M16  
 Max. fixture thickness:  $t_{fix}$   
 Material<sup>\*1)</sup>: HCR

Examples: BAZ: S-KA 10/20 - zinc plated  
 BAZ HD: S-KAK 10/20 - hot dip galvanized  
 BAZ A4: S-KAH 10/20 - stainless steel A4  
 BAZ HCR: S-KAH 10/20 HCR - stainless steel HCR

<sup>\*1)</sup>: Where applicable

### Apolo MEA Quick fix anchor after installation

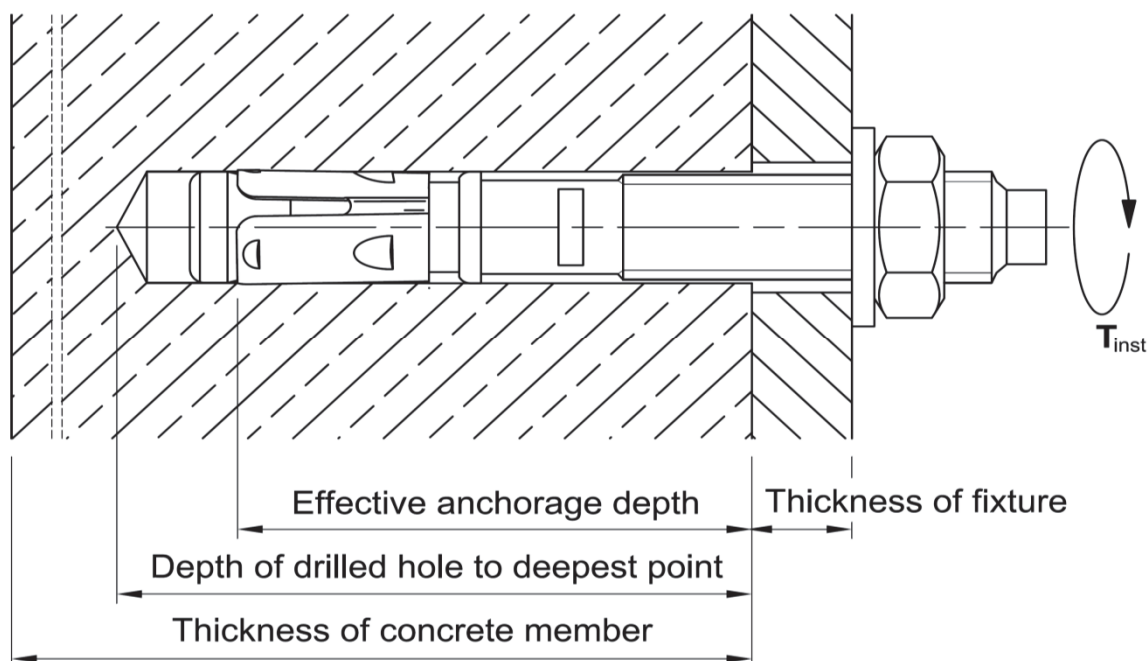

<b>Apolo MEA Quick fix anchor</b>	<b>Annex 1</b> of European Technical Approval <b>ETA - 10 / 0280</b>
Product and intended use	

## Apolo MEA Quick fix anchor

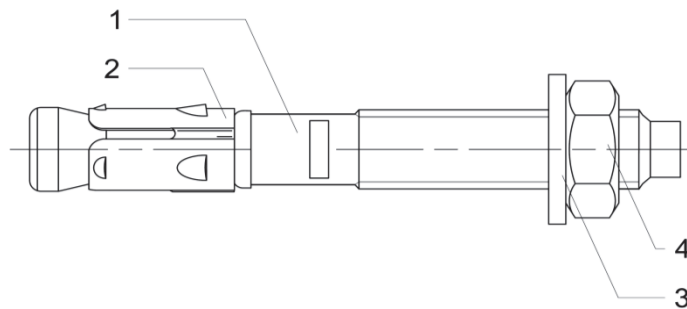

**Table 1a: Materials BAZ and BAZ HD**

Part	Designation	Diameters	Material <sup>1) 2)</sup>	$f_{yk}$ [N/mm <sup>2</sup> ]	$f_{uk}$ [N/mm <sup>2</sup> ]
1	Bolt	M10 + M12	Cold forged steel, EN 10263-2	560	660
		M8 + M16		475	560
2	Sleeve	M8 - M16	Cold rolled galvanized steel strip, EN 10147		
3	Washer	M8 - M16	Electroplated steel, DIN 125 (EN ISO 7089), DIN 440 (EN ISO 7094), DIN 9021 (EN ISO 7093)		
4	Hexagonal Nut	M8 - M16	Steel, electroplated, grade 8, DIN 934 (EN ISO 4032)		

<sup>1)</sup> **BAZ:** Parts 1, 3 and 4 are zinc electroplated according to EN ISO 4042  $\geq 5\mu\text{m}$  and bright passivated.

<sup>2)</sup> **BAZ HD:** Parts 1, 3 and 4 are hot dip galvanized according to EN ISO 10684.

**Table 1b: Materials BAZ A4**

Part	Designation	Diameters	Material	$f_{yk}$ [N/mm <sup>2</sup> ]	$f_{uk}$ [N/mm <sup>2</sup> ]
1	Bolt	M8 - M16	Cold forged stainl. steel, EN 10088-3 1.4578	530	600
2	Sleeve	M8 - M16	Stainless steel strip, EN 10088-2 W 1.4401 / 1.4404 / 1.4571		
3	Washer	M8 - M16	Stainless steel, W 1.4401 / 1.4404 / 1.4571, DIN 125 (EN ISO 7089), DIN 440 (EN ISO 7094), DIN 9021 (EN ISO 7093)		
4	Hexagonal Nut	M8 - M16	Stainless steel, grade 80, W 1.4401 / 1.4404 / 1.4571 DIN 934 (EN ISO 4032)		

**Table 1c: Materials BAZ HCR**

Part	Designation	Diameters	Material	$f_{yk}$ [N/mm <sup>2</sup> ]	$f_{uk}$ [N/mm <sup>2</sup> ]
1	Bolt	M8 - M16	Cold forged stainl. steel, EN 10088-3 1.4529 / 1.4565	530	600
2	Sleeve	M8 - M16	Stainless steel strip, EN 10088-2 W 1.4401 / 1.4404 / 1.4571		
3	Washer	M8 - M16	Stainless steel, W 1.4529 / 1.4565, DIN 125 (EN ISO 7089), DIN 440 (EN ISO 7094), DIN 9021 (EN ISO 7093)		
4	Hexagonal Nut	M8 - M16	Stainless steel, grade 80, W 1.4529 / 1.4565 DIN 934 (EN ISO 4032)		

**Apolo MEA Quick fix anchor**

Materials

**Annex 2**

of European  
Technical Approval  
**ETA - 10 / 0280**

## Apolo MEA Quick fix anchor

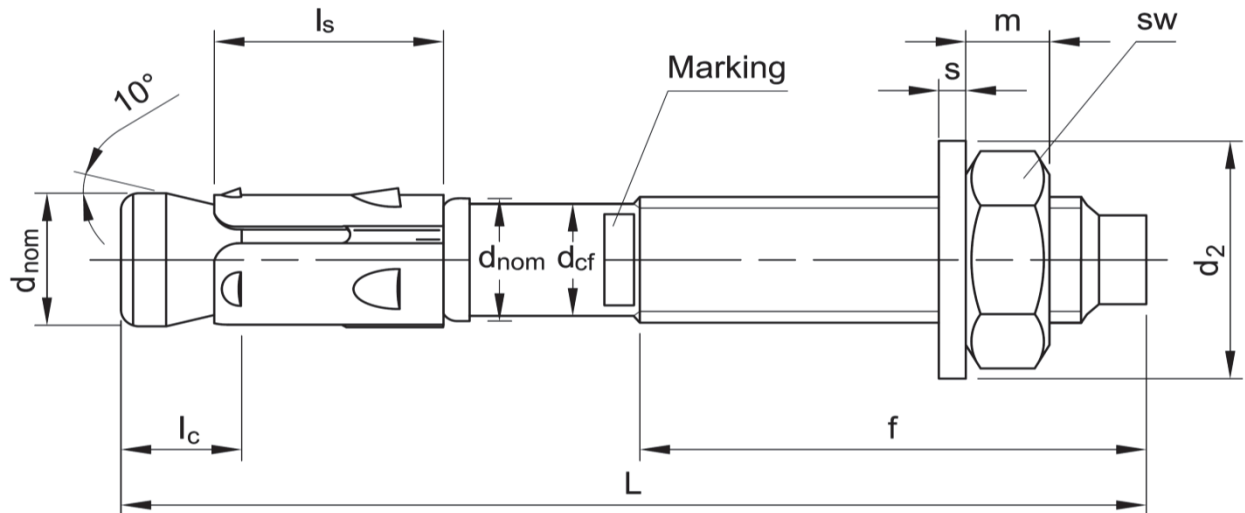

Table 2: Dimensions of the anchor

Main dimensions			Stud bolt		Cone bolt		Expansion sleeve	Washer			Hexagonal nut	
Anchor type	Size	L [mm]	f [mm]	d <sub>cf</sub> [mm]	d <sub>nom</sub> [mm]	l <sub>c</sub> [mm]	l <sub>s</sub> [mm]	s [mm]	d <sub>1</sub> [mm]	d <sub>2</sub> [mm]	sw [mm]	m [mm]
8 / 0.....358	M8	62...420	22...220	7,1	8	20,9	15,9	≥1,6	≥8,4	≥16	13	≥6,5
10 / 0.....338	M10	82...420	37...215	9,0	10	25,7	17,9	≥2,0	≥10,5	≥20	≥16	≥8,0
12 / 0.....322	M12	98...420	48...210	10,8	12	30,3	19,1	≥2,5	≥13,0	≥24	≥18	≥10,0
16 / 0.....302	M16	118...420	60...202	14,6	16	38,1	26,3	≥3,0	≥17,0	≥30	24	≥13,0

**Apolo MEA Quick fix anchor**

Dimensions of the anchor

**Annex 3**

of European  
Technical Approval  
**ETA - 10 / 0280**

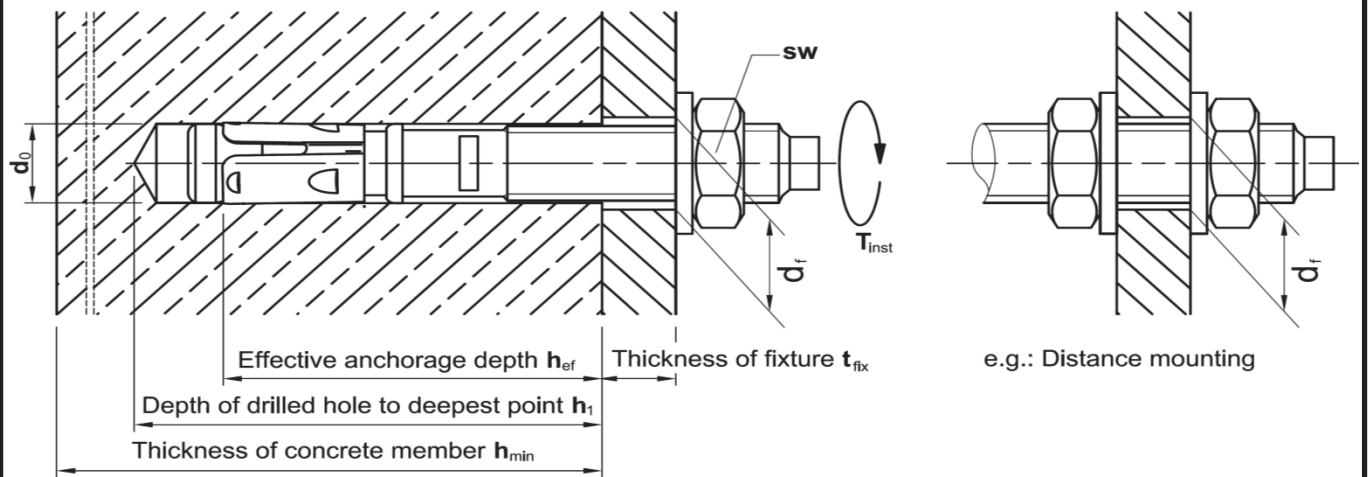

**Table 3: Installation data**

Apolo MEA Quick fix anchor		Anchor size			
		M8	M10	M12	M16
Drill hole diameter	$d_0$ [mm]	8	10	12	16
Cutting diameter at the upper tolerance limit (maximum diameter bit)	$d_{cut,max} \leq$ [mm]	8,45	10,45	12,5	16,5
Depth of drilled hole to deepest point	$h_1 \geq$ [mm]	60	75	90	110
Effective anchorage depth	$h_{ef}$ [mm]	45	60	70	85
Diameter of clearance hole in the fixture	$d_f \leq$ [mm]	9	12	14	18
Thickness of fixture	$t_{fix,min...max}$ [mm]	0...358	0...338	0...322	0...302
Width across flats	SW [mm]	13	$\geq 16$	$\geq 18$	24
Required torque	$T_{inst}$ [Nm]	20 / 15 <sup>1)</sup>	35	50	120
		20	35	70	120

<sup>1)</sup> Installation torque for BAZ is 20 Nm and for BAZ HD 15 Nm

**Table 4: Minimum thickness of concrete member, spacing and edge distance**

Apolo MEA Quick fix anchor		Anchor size			
		M8	M10	M12	M16
Minimum thickness of concrete member	$h_{min}$ [mm]	100	120	140	170
Minimum spacing	$s_{min}$ [mm]	50	55	60	70
	$c \geq$ [mm]	50	80	90	120
Minimum edge distance	$c_{min}$ [mm]	50	50	55	85
	$s \geq$ [mm]	50	100	145	150

Intervals may be interpolated linearly.

<b>Apolo MEA Quick fix anchor</b>	<b>Annex 4</b> of European Technical Approval <b>ETA - 10 / 0280</b>
Installation data, Minimum thickness of concrete member, Spacing and edge distance	

**Table 5: Design method A - Characteristic values for tension loads**

Apolo MEA Quick fix anchor			Anchor size			
			M8	M10	M12	M16
<b>Steel failure</b>						
Characteristic resistance BAZ / BAZ HD	$N_{Rk,s}$	[kN]	13	26	38	69
Characteristic resistance BAZ A4 / BAZ HCR	$N_{Rk,s}$	[kN]	15	24	35	75
Partial safety factor	$\gamma_{Ms}$ <sup>1)</sup>	[-]	1,40			
<b>Pull-out failure</b>						
Characteristic resistance in <b>cracked</b> concrete C20/25	$N_{Rk,p}$	[kN]	5	9	12	20
Characteristic resistance in <b>non cracked</b> concrete C20/25	$N_{Rk,p}$	[kN]	9	16	20	35
Increasing factor for $N_{Rk,p}$	$\psi_C$	C25/30	1,04			
		C30/37	1,10			
		C35/45	1,16			
		C40/50	1,20			
		C45/55	1,24			
		C50/60	1,28			
Partial safety factor	$\gamma_{Mp}$ <sup>1)</sup>	[-]	1,80 <sup>2)</sup>			1,50 <sup>3)</sup>
<b>Concrete cone failure</b>						
Effective anchorage depth	$h_{ef}$	[mm]	45	60	70	85
Spacing	$s_{cr,N}$	[mm]	135	180	210	255
Edge distance	$c_{cr,N}$	[mm]	68	90	105	128
Partial safety factor	$\gamma_{Mc}$ <sup>1)</sup>	[-]	1,80 <sup>2)</sup>			1,50 <sup>3)</sup>
<b>Concrete splitting failure</b>						
Spacing ( splitting )	$s_{cr,sp}$	[mm]	180	240	280	340
Edge distance ( splitting )	$c_{cr,sp}$	[mm]	90	120	140	170
Partial safety factor	$\gamma_{Msp}$ <sup>1)</sup>	[-]	1,80 <sup>2)</sup>			1,50 <sup>3)</sup>

<sup>1)</sup> In absence of other national regulations.

<sup>2)</sup> The installation safety factor of  $\gamma_2 = 1,2$  is included.

<sup>3)</sup> The installation safety factor of  $\gamma_2 = 1,0$  is included.

**Table 6: Displacements under tension loads**

Apolo MEA Quick fix anchor			Anchor size			
			M8	M10	M12	M16
Cracked and non-cracked concrete C20/25 - C50/60	N	[kN]	2,0	3,6	4,8	9,5
	$\delta_{N0}$	[mm]	0,3	0,6	0,6	0,7
	$\delta_{N\infty}$	[mm]	1,8	1,6	2,0	1,4

**Apolo MEA Quick fix anchor**

Design method A :  
Characteristic values for tension loads and displacements

**Annex 5**

of European  
Technical Approval  
**ETA - 10 / 0280**

**Table 7: Design method A - Characteristic values for shear loads**

Apolo MEA Quick fix anchor			Anchor size			
			M8	M10	M12	M16
<b>Steel failure without lever arm</b>						
Characteristic resistance BAZ / BAZ HD	$V_{RK,s}$	[kN]	10	18	23	44
Characteristic resistance BAZ A4 / BAZ HCR	$V_{RK,s}$	[kN]	11	17	25	47
Partial safety factor	$\gamma_{Ms}^{1)}$	[-]	1,50			
<b>Steel failure with lever arm</b>						
Characteristic resistance BAZ / BAZ HD	$M_{RK,s}^0$	[Nm]	21	48	72	186
Characteristic resistance BAZ A4 / BAZ HCR	$M_{RK,s}^0$	[Nm]	22	45	79	200
Partial safety factor	$\gamma_{Ms}^{1)}$	[-]	1,50			
<b>Concrete pryout failure</b>						
Factor in equation ( 5.6 ) of ETAG Annex C, § 5.2.3.3	k	[-]	1	2		
Partial safety factor	$\gamma_{Mc}^{1)}$	[-]	1,50			
<b>Concrete edge failure</b>						
Effective length of anchor under shear load	$l_f$	[mm]	45	60	70	85
Outside diameter of anchor	$d_{nom}$	[mm]	8	10	12	16
<b>Cracked concrete</b> without any edge reinforcement	$\Psi_{ucr,V}$	[-]	1,00			
<b>Cracked concrete</b> with straight edge reinforcement > Ø12 mm			1,20			
<b>Cracked concrete</b> with edge reinforcement and closely spaced stirrups ( $a \leq 100\text{mm}$ ) or <b>non cracked concrete</b>			1,40			
Partial safety factor	$\gamma_{Mc}^{1)}$	[-]	1,50			

<sup>1)</sup> In absence of other national regulations.

**Table 8: Displacements under shear loads**

Apolo MEA Quick fix anchor			Anchor size			
			M8	M10	M12	M16
Cracked and non-cracked concrete C20/25 - C50/60	V	[kN]	5,7	10,3	13,1	25,1
	$\delta_{V0}$	[mm]	1,7	1,7	2,4	3,2
	$\delta_{V\infty}$	[mm]	2,6	2,6	3,6	4,8

**Apolo MEA Quick fix anchor**

Design method A:  
Characteristic values for shear loads and displacements

**Annex 6**

of European  
Technical Approval  
**ETA - 10 / 0280**

**Table 9: Design method A - Characteristic tension resistance in cracked and non-cracked C20/25 to C50/60 under fire exposure**

Apolo MEA Quick fix anchor		Anchor size																							
		M8			M10			M12			M16														
Fire resistance duration	R... [min]	30	60	90	120	30	60	90	120	30	60	90	120	30	60	90	120								
<b>Steel failure</b>																									
Characteristic resistance $N_{Rk,s,fi}$ [kN]	BAZ / BAZ HD	1,3	0,7	0,4	0,3	2,3	1,3	0,8	0,5	3,6	2,0	1,3	0,9	5,3	3,0	1,8	1,3								
	BAZ A4 / BAZ HCR	5,7	3,9	2,0	1,1	9,1	6,1	3,2	1,8	13,2	8,9	4,7	2,6	24,5	16,6	8,7	4,8								
<b>Pull-out failure</b>																									
Characteristic resistance	$N_{Rk,p,fi}$ [kN]	1,3			1,0			2,3			1,8			3,0			2,4			5,0			4,0		
<b>Concrete cone failure</b>																									
Characteristic resistance	$N^0_{Rk,c,fi}$ [kN]	2,4			2,0			5,0			4,0			7,4			5,9			12,0			9,6		
Spacing	$S_{cr,N}$ [mm]	4 x $h_{ef}$																							
	$S_{min}$ [mm]	50			55			60			70														
Edge distance	$C_{cr,N}$ [mm]	2 x $h_{ef}$																							
	$C_{min}$ [mm]	Fire attack from one side: $C_{min} = 2 \times h_{ef}$ Fire attack from more than one side: $C_{min} \geq 300$ mm																							

In absence of other national regulations the partial safety factor for resistance under fire exposure  $\gamma_{M,fi} = 1,0$  is recommended.

### Apolo MEA Quick fix anchor

Characteristic values of tension load resistance under fire exposure

### Annex 7

of European  
Technical Approval  
**ETA - 10 / 0280**

**Table 10: Design method A - Characteristic shear resistance in cracked and non-cracked C20/25 to C50/60 under fire exposure**

Apolo MEA Quick fix anchor		Anchor size																							
		M8			M10			M12			M16														
Fire resistance duration	R... [min]	30	60	90	120	30	60	90	120	30	60	90	120	30	60	90	120								
<b>Steel failure without lever arm</b>																									
Characteristic resistance $V_{Rk,s,fi}$ [kN]	BAZ / BAZ HD	1,3	0,7	0,4	0,3	2,3	1,3	0,8	0,5	3,6	2,0	1,3	0,9	5,3	3,0	1,8	1,3								
	BAZ A4 / BAZ HCR	5,7	3,9	2,0	1,1	9,1	6,1	3,2	1,8	13,2	8,9	4,7	2,6	24,5	16,6	8,7	4,8								
<b>Steel failure with lever arm</b>																									
Characteristic resistance $M^0_{Rk,s,fi}$ [Nm]	BAZ / BAZ HD	1,8	1,3	0,8	0,6	3,6	2,6	1,6	1,1	6,4	4,6	2,8	1,9	16,2	11,7	7,2	4,9								
	BAZ A4 / BAZ HCR	5,8	4,0	2,1	1,1	11,7	7,9	4,2	2,3	20,4	13,9	7,3	4,0	52,0	35,2	18,5	10,2								
<b>Concrete pryout failure</b>																									
Factor in equation (5.6) of ETAG 001 Annex C, 5.2.3.3	k [-]	1,0			2,0			2,0			2,0			2,0											
Characteristic resistance	$V^0_{Rk,op,fi}$ [kN]	2,4			2,0			10,0			8,0			14,8			11,8			24,0			19,2		
<b>Concrete edge failure</b>																									
<p>The initial value <math>V^0_{Rk,c,fi}</math> of the characteristic resistance in concrete C20/25 to C50/60 under fire exposure may be determined by:</p> $V^0_{Rk,c,fi} = 0,25 \times V^0_{Rk,c} \quad (\leq R90) \quad V^0_{Rk,c,fi} = 0,20 \times V^0_{Rk,c} \quad (R120)$ <p>with <math>V^0_{Rk,c}</math> initial value of the characteristic resistance in cracked concrete C20/25 under normal temperature.</p> <p>In absence of other national regulations the partial safety factor for resistance under fire exposure <math>\gamma_{M,fi} = 1,0</math> is recommended.</p>																									

### Apolo MEA Quick fix anchor

Characteristic values of shear load resistance under fire exposure

### Annex 8

of European  
Technical Approval  
**ETA - 10 / 0280**